

SDS MODEL 9164/9165 DISC FILE MASS MEMORY SYSTEM

The SDS Model 9164/9165 Disc File Mass Memory System is a large-capacity, auxiliary memory with low access time and advanced operational characteristics for applications requiring large amounts of random access storage. The SDS disc file system is functionally and electrically compatible with all 900 Series computers (except the SDS 910 and SDS 920) and with the SDS 9300 computer. A system consists of one Model 9164 Disc File Controller and one Model 9165 Disc File Storage Module.

Model 9165 Disc File Storage Modules are available in two versions, each providing a storage capacity of 67.1 million characters: Model 9165-14 is a single-access file storage unit with 32 discs; Model 9165-24 is a storage unit equipped with a dual-access feature that provides two simultaneous Read/Write/Seek operations when connected to separate channels. The simultaneous Read/Write/Seek feature is only possible, however, when the discs involved are located in separate sections of the file as illustrated in Figure 1.

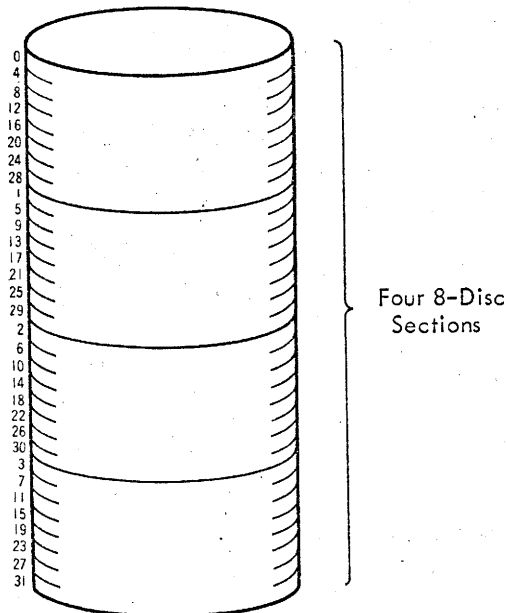

Figure 1. Disc Numbering — For programming purposes, the discs are numbered so that 0-3, 4-7, ..., 28-31 reside in four different sections of the file

Single- and dual-access versions of the Model 9164 Controller are also available: Model 9164-01 is a single-access controller; Model 9164-02 is a dual-access controller.

The Model 9164-01 provides all the necessary control and interface logic to connect a disc storage module to the SDS computer's input/output channel. The Model 9164-02 provides (1) the same capability for a disc storage module equipped with the dual-access feature and (2) two independent sets of input/output channel connections.

File unit addresses are set manually by switches in each controller. The four possible addresses are 22, 23, 26, and 27.

Among the several methods of using the dual-access features to best advantage are the following:

1. Two computers can be linked together through the disc file system. Each can be seeking, reading, or writing at the same time (Figure 2).

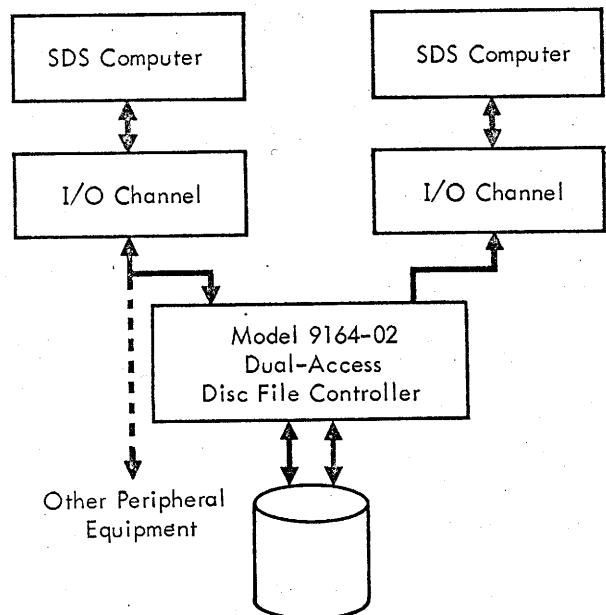

Figure 2. Two SDS Computers Sharing a Dual-Access Disc File System

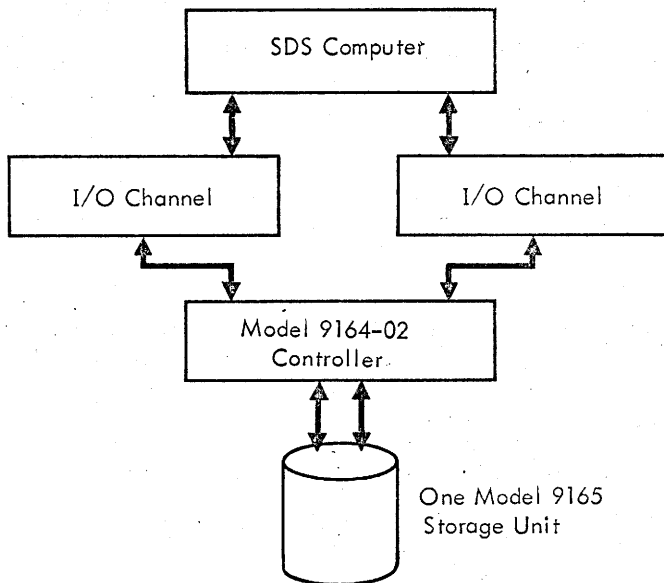

Figure 3. One SDS Computer with Dual Operation of File Storage Unit

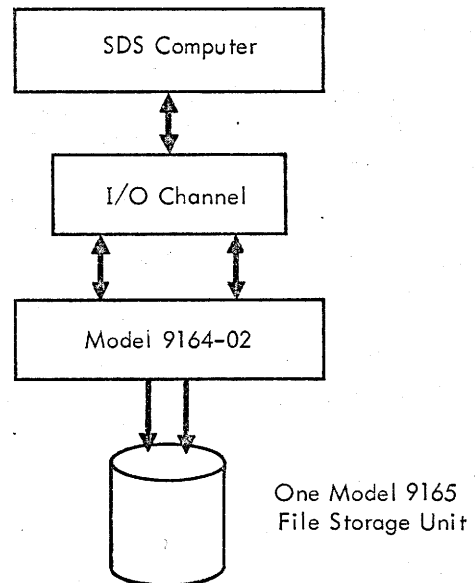

Figure 4. SDS Computer with Overlap of Seek and Read/Write Disc Operations

2. One computer can have dual access to one file system by connecting a Model 9164-02 Controller to two input/output channels, thereby allowing any two operations (Seek/Read/Write) simultaneously (Figure 3).

3. Both controller access connections can be attached to a single computer input/output channel (Figure 4). One access control can be seeking a specified track while the other is used for a Seek/Read/Write, thereby providing overlap of Seek and Seek/Read/Write. However, two Read/Write operations cannot occur simultaneously in this configuration.

MODEL 9164 DISC FILE CONTROLLERS

The Model 9164-01 Disc File Controller couples and controls a Model 9165-14 (single-access) Disc File Storage Unit through one input/output channel of the SDS computer.

The Model 9164-02 Disc File Controller is used in systems that have the dual-access file storage unit (Model 9165-24) and provides connections to two SDS computer input/output channels and to two file storage units.

Standard unit address code assignments for the computer input/output channels provide for four single-access disc file controllers. Thus, eight input/output channels can accommodate 32 Model 9164-01 Disc File Controllers, each of which can control a disc file storage module.

MODEL 9165 DISC FILE STORAGE MODULES

Two types of disc file storage modules are available: the Model 9165-14 is a single-access unit with 32 discs; the Model 9165-24 is a dual-access unit, also with 32 discs.

The following features apply to both types of storage units:

Disc Diameter:	31 in.
Rotational Speed:	1152 rpm
Rotational Latency:	26 msec av. 52 msec max.
Positioning Latency:	35 msec min. 225 msec max.
Track Density:	26.7 tracks/in.
Recording Density:	600 bits/in. (nominal)
Recording Mode:	Frequency Doubling, bit serial
Transfer Rate:	
(6-bit characters/sec)	60kc minimum 79kc average (track pair) 111kc maximum

Specific characteristics of the Single Access (Model 9165-14) and Dual Access (Model 9165-24) File Storage Units are:

Number of Access Arms and Discs	32
Storage Capacity (words)	16,777,216
Storage Capacity (alphanumeric characters)	67,108,864

An SDS Model 9165 Disc File Storage unit consists of (1) 32 magnetically coated discs, which store data, and (2) additional baffle discs, which supply timing and control information to the Model 9164 Controller. Each disc provides two recording surfaces. Each access arm has a separate and independent positioning mechanism. Eight Read/Write heads are mounted on each access arm: four for the bottom surface and four for the top surface (Figure 5).

The control surfaces are not available to the programmer.

Each recording surface is divided into two zones, outer and inner, of 128 information tracks. Each outer track is divided into 20 recording sectors of 64 words (256 alphanumeric characters). Inner tracks are divided into 12 sectors of 64 words each.

For each recording surface, two of the read/write heads are used for outer zone tracks, two for inner zone tracks. The positioner can move the access arm to any of 64 discrete positions.

The entire information content on a disc surface is available by moving the access arm a maximum of 4.725 inches.

Two tracks, one outer and one inner, are logically joined to form a track pair of 32 sectors (20 plus 12).

Therefore, two disc revolutions are required to read or write a track pair (Figure 6). Four track pairs (two per surface) can be read or written without repositioning the access arm.

Addressing is contiguous (monotonically increasing) throughout the file.

The sector is the physical unit of recorded information, and every read or write operation must start at the beginning of a sector. However, sectors are logically subdivided into subsectors (packets) of 16 words each. A sector is composed of one to four 16-word packets and, therefore, contains 16, 32, 48, or 64 data words. If the

computer does not provide an integer multiple of 64 words during a Write operation, the remaining words of the last packet are recorded as zeros. A check character (longitudinal parity of all characters in the sector) is written for each sector. A Chain Bit can be written after the check character. See Figure 7 for a diagrammatic description.

A packet bit is recorded after each packet written. The packet bit is automatically recorded by the controller as a one bit, except for the last packet of a sector, which is recorded as a zero bit. The check character and the chain bit are also recorded after the packet with a zero packet bit. This permits the controller, during a read, to transmit and verify data before reaching the physical sector mark when fewer than four packets are written. It also minimizes channel utilization.

Inclusion of the chaining feature in the SDS disc file system permits variable length Read and Write operations, thereby providing greater flexibility in file design and conservation of computer memory space. A chain is a group of contiguous sectors that are considered as a logical unit or record for processing and transmission purposes. The Chain Bit of a sector that is not the last sector of the record is recorded as a one. The Chain Bit of the last sector of a record is recorded as a zero.

A Chain Read operation reads from sector to sector until the End-of-Chain is encountered (Chain Bit equal to zero or otherwise terminated by the program or "word count zero" condition). Automatic repositioning of the access arms and switching from access arm to access arm is provided during chained operations.

ACCESS TIME

The access time to any one sector is a function of the distance that the access arm is moved. If the sector to be read or written is one of the four Logical Track Pairs that can be accessed without moving the selected access arm, the average access time is 26 milliseconds; and the maximum access time is 52 milliseconds, or one disc revolution.

If the access arm must be moved, the maximum positioning time never exceeds 325 milliseconds. This time includes 225 milliseconds to move the arm, 50 milliseconds to ensure that it has settled on the selected track and 50 milliseconds to locate the proper sector.

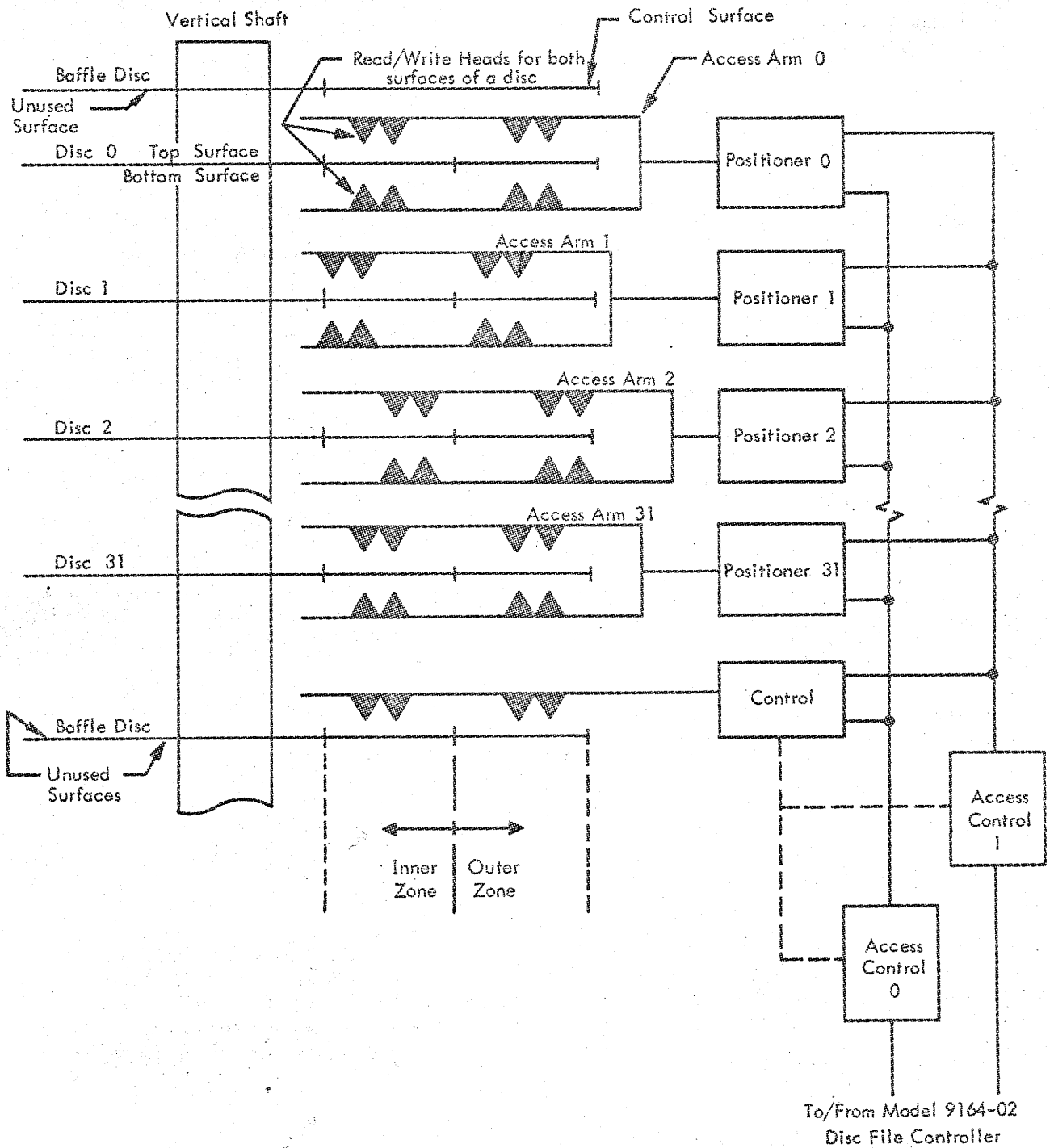

Figure 5. SDS Model 9165-24 Disc File Storage Module

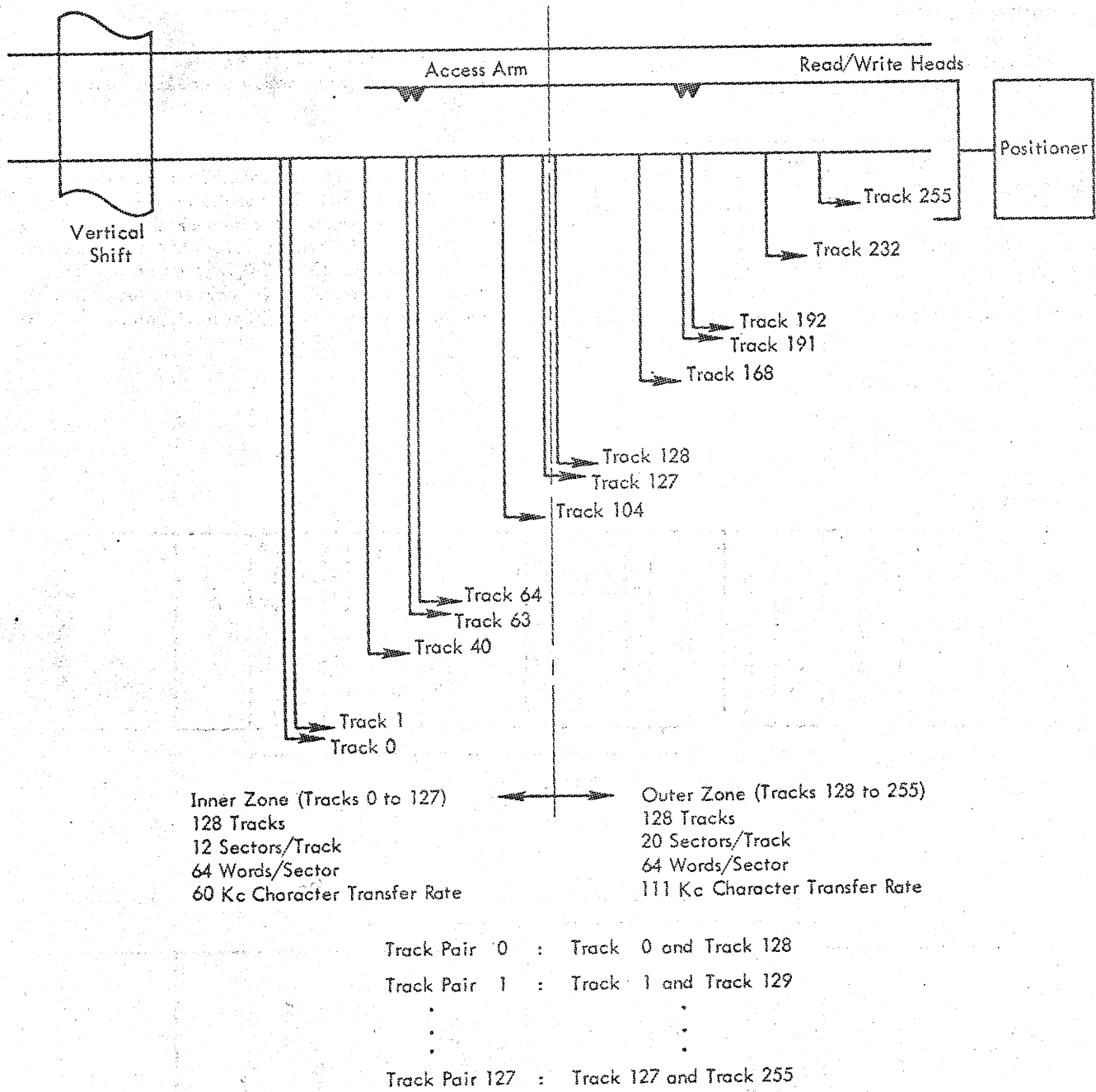
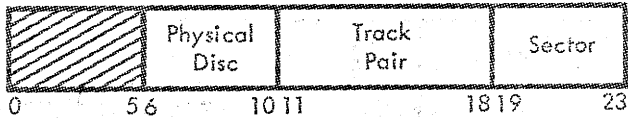

Figure 6. Organization of Model 9165 Inner/Outer Recording Zones and Track Pairs

DISC ADDRESS WORD

The disc address word is divided into four sections as shown below. The first five bits are not used.



Physical Disc

Bits 6-10 specify one of the 32 discs in the file unit.

Track Pair

Bits 11-18 specify one of the 256 track pairs on the disc. A track pair consists of one outer and one inner track.

Sector

Bits 19-23 specify one of the 32 sectors in each logical track pair. Each sector consists of one to four 16-word packets plus a check character for the entire sector. Sectors 0-19 (00-23/8) are on the outer track and sectors 20-31 (24-37/8) are on the inner track. Two disc revolutions are required to access the 32 sectors on one logical track pair.

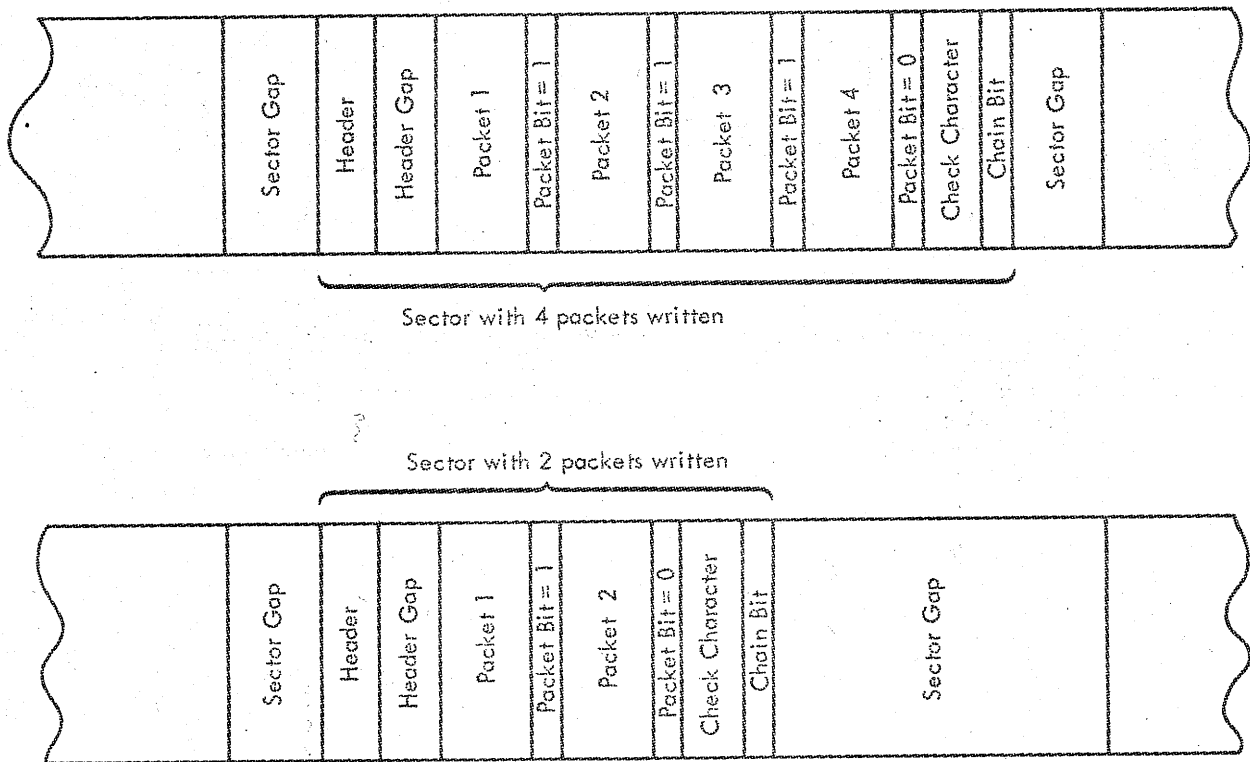

Figure 7. Organization of a Sector

PROGRAMMING CONSIDERATIONS, DISC FILE

SKS Instructions

Five tests enable users to determine status of a movable head controller. The SKSs listed below test unit address 26 on Channel A.

Controller Ready Test — SKS 10026. The disc file controller provides a Ready signal to the computer, which causes the SKS instruction to skip if the controller can accept an address word. The controller signals Not Ready for the following operational reasons:

1. Reading or writing;
2. Seeking (arm in motion);
3. Waiting to gain control of a positioner;
4. Write monitor error; or
5. Error counter not zero and stop-on-error switch in STOP position.

Controller Error Test — SKS 11026. An error is posted when:

1. Time to seek and verify a track and disc address exceeds a reasonable value;
2. Time to search for a specific sector exceeds two disc revolutions; or
3. Write monitor fails to indicate proper level during reading or writing.

If one or more of these errors occur, an error line is energized and is tested by SKS 11026. If no error condition exists, the SKS instruction skips. An ALERT EOM instruction followed by a POT instruction clears all but the write monitor error.

Track Verified Test — SKS 12026. Skip if positioner is on addressed track and read-write electronics are connected to the addressed disc.

File Protect Test — SKS 13026. The disc controller supplies a signal to the computer, which can be tested to determine whether the physical disc (addressed by bits 6-10) currently selected is protected from writing. Each

access arm has a manual switch, which allows reading and writing or, in the alternate position, inhibits writing on that disc. The SKS instruction skips if the disc is not write protected.

File On Line Test — SKS 10226. The instruction skips if the file is "on line," meaning that the file is operable and capable of receiving commands from the controller.

Channel Errors

If either of the following occurs, it is reported as a channel error:

1. The longitudinal check character or its odd parity bit is not verified during a read operation; or
2. The character odd parity value from the buffer channel does not check with odd parity on the same character generated when character shifts onto disc during a write operation.

Disc Operations

The instructions that follow apply for controller unit addresses 26 (for reading) and 66 (for writing) when connected to channel A. Other TMCC channels are specified by other configurations of bits 1 and 17 of the EOM. DACC channels are similarly specified using EOD in place of EOM.

Alert to Accept or Send Address (EOM 10026). This disc file controller is notified that the computer is transmitting an address with the ALERT EOM. Following this, the program executes a POT to transmit the address word. If the controller is not ready when the POT occurs, program execution is delayed until the file controller accepts the word and acknowledges the POT.

This instruction also alerts the controller for a PIN instruction, which transmits the address in the controller address register to computer memory. The PIN operation can be done at any time.

Seek and Verify. The Seek and Verify operation is initiated by an ALERT EOM/POT sequence. Once the controller has received the address, it signals Not Ready until the specified arm has been moved to the selected position and the position is verified. If the computer has not addressed the unit for a Read or Write by this time, the controller continues to verify and hold its position.

During this time, the other access control arm may gain control of the same access arm if it is waiting for control of this arm. An optional feature is available to provide an interrupt signal when the controller has verified the position of the access arm. The interrupt (if present) will occur for two reasons:

1. Track verification successful; or
2. Seek time elapsed.

Write. Before a Write is attempted, the programmer should determine that the physical disc selected is not write-protected. This is accomplished by testing the File Protect signal after sending the address to the controller. This signal can be tested even though the coupler has not yet moved the selected access arm to the correct track.

After the controller has verified the position of the access arm, it examines the unit address register in the input/output channel to see if it is being addressed by the computer. If the controller is addressed for a Write, it begins writing at the specified sector. If a Write operation should terminate before the end of a packet, the controller continues to write zeros until the end of that packet. The controller signals Not Ready after a Write until the check character for the last sector addressed is written.

An attempt to write on a protected disc will not result in an error, and no change occurs in the information recorded on the disc.

When setting up the interlace and terminal operations, IOSD must be used for writing.

Two Write operations are available:

IOSD FOM 1A2XX

1. Write Disc Sectors (EOM 03666). Starting at the sector addressed, the disc writes the output words until the I/O channel disconnects. At the end of each sector the Chain Bit is recorded as a one. When all output is completed, the controller fills in the last packet with zeros, if necessary, and again records the Chain Bit as a one. This means that, on chain input, no sector written with a WDS will indicate End-of-Chain.

2. Write Disc Chain (EOM 02666). Starting at the sector addressed, the controller writes the output words until the I/O channel disconnects. If at the end of a sector more output is to follow, the controller writes the Chain Bit as a one. When all output is finished, the controller fills in the last packet with zeros, if necessary, and records the sector check character followed by a

Chain Bit of Zero. This sector indicates End-of-Chain on input.

Writing is not terminated or altered by the detection of a sector gap in either of the preceding operations.

Read. A Read operation is executed by sending the address for a Seek and Verify and then setting up the channel with a disc read. When the controller verifies that the access arm is settled on the track, it looks at the unit address register. Since this now is a disc read, the controller locates the sector specified and begins transmission. At the end of the sector, the disc address in the controller is incremented; and the controller reads the next sector if it is still selected by the unit address. The access arm is relocated automatically, if required. An access arm is also selected, positioned, and settled on the next physical disc automatically. This operation can be delayed if the access arm is being used by the other access control.

When setting up the interlace and terminal orders, IORD must be used for reading.

As with write, there are two read operations: one for sectors and one for chains:

IORD FOM 1A0XX

1. Read Disc Sector (EOM 03626). Starting at the sector addressed, the controller reads characters until the end of the sector is encountered. It then verifies the check character; sets the error indicator, if necessary, and signals End-of-Record. The sector read can consist of from one to four packets (16, 32, 48, or 64 words).

2. Read Disc Chain (EOM 02626). Starting at the sector addressed, the controller reads characters until the End-of-Sector is encountered. It then verifies the check character; sets the error indicator, if necessary; and inspects the chain bit. If the chain bit is a one, the Read continues to the next sector. This is repeated until a sector is encountered whose Chain Bit is a zero. At that point, the controller signals End-of-Record and transmission stops. Each sector Read can consist of one to four packets. There is no limit to the number of sectors that can be in the chain.

With either Read operation, if the count goes to zero before the end of sector in an RDS or before End-of-Chain is encountered in an RDC, the controller terminates transmission and, at the end of the current sector, sends an End-of-Record Signal.

* * *

For other programming considerations, see the programming manual for the appropriate SDS central processor.